



INSTRUCTIONS

SOLID-STATE DECOUPLER (SSD)



INTRODUCTION

The Solid-State Decoupler (SSD) is a solid-state DC isolation/AC grounding (i.e., coupling) device designed for use in conjunction with cathodically protected equipment located in Class I, Division 2 hazardous (classified) locations or ordinary (non-hazardous) locations. The SSD is suitable for: (1) decoupling ground mats, (2) AC voltage mitigation, (3) over-voltage protection of isolation joints and similar structures and equipment, (4) DC isolation and AC grounding of cathodically protected structures and electrical equipment in cathodically protected structures.

The SSD can be used in a variety of different applications, each of which requires specific installation guidelines. These installation instructions cover the following common applications and arrangements.

- Over-voltage protection for isolation joints
- Decoupling gradient control mats
- Decoupling cathodically protected structures containing electrical equipment from grounding systems
- AC mitigation

Some applications listed may not apply in some countries due to different codes and practices. If your application is not covered by these installation instructions, contact Dairyland.

Technical information for applications is available on the Dairyland website.

WARNING

During installation, the voltage on the structure may rise to an unsafe level (i.e., due to induced AC, AC fault or lightning on the structure). Sparking and current flow may occur when connecting or disconnecting decouplers or over-voltage protectors. Assure that this does not occur in hazardous locations where gases or vapors may be present. All necessary safety precautions must be taken by the user to avoid unsafe worker conditions, including arcing, in accordance with applicable industry and/or company-required practices. Dairyland provides suggested procedures for installing and operating this equipment (See the section on Worker Safety) but the user must be responsible for and approve the procedures to be used by its workers when installing the equipment because Dairyland cannot be familiar with each user's safety guidelines.

WARNING

Note: Explosion Hazard - Substitution of any component may impair suitability for Class I, Division 2.

READ ENTIRE DOCUMENT BEFORE INSTALLING

INSTALLATION INSTRUCTIONS

These general instructions apply to all applications.

Worker Safety

For worker safety during installation or removal, it is recommended that the user obtain certain equipment; namely a pair of electrically isolation gloves, a shorting cable approximately 3ft (0.91m) long with isolation clamps on each end, and a multi-meter to measure AC voltage. (Of these items, Dairyland offers a suitable 3ft long 1/0AWG shorting cable with isolation clamps, Model# BCL-1/0 for all decoupler ratings.) The following installation procedure assumes that these items are available. It is suggested that a grounding jumper be used as a safety precaution in the event the lead to the structure rises to an unsafe potential when it is disconnected during the installation or removal process or if an electrical disturbance occurs while the decoupler is being installed. Be sure to remove the grounding jumper after the decoupler is completely installed. If the structure voltage is not at a safe touch potential (i.e., >15VAC to ground per NACE SP0177), then insulating gloves should be used.



Mounting

Mount the SSD so that the total length of conductor to the connection points will be as short as possible if the SSD is going to be used to provide over-voltage protection from lightning. All conductors have inductance which will cause a significant voltage per unit of conductor length when subject to lightning impulse current. To minimize the voltage developed between the connection points, install the SSD as close as practical to the required connection points and cut the conductor to the shortest possible length during installation. For most isolation joint applications the SSD can, and should, be installed with less than 8" (200 mm) of conductor. Conductors can develop 1-3 kV/ft. (approx. 3-10 kV/meter) of length due to lightning; hence, for this reason, leads should be kept as short as possible in lightning applications. Conductor length is not critical for limiting voltage due to 50 Hz or 60 Hz current.

Mounting Accessories

Numerous mounting accessories are available from Dairyland to aid in the proper installation of the PCR. Full details and complete installation instructions are available on the Dairyland website here: [Dairyland Accessories](#).

Specific Installation Guidance

The Dairyland website contains detailed information on the installation methods specific to a given application. For wiring diagrams and/or application guidance, see [Dairyland Applications](#).

Environmental Exposure

The SSD enclosure is rated IP68 and is suitable for indoor or outdoor use, in submersible and non-submersible applications. SSDs may be submersed in non-freezing conditions up to 6.5ft. (2m) depth for occasional prolonged periods, though not continuously.

The unit must be installed in environments with ambient temperatures of -49°F to +149°F (-45°C to +65°C).

Polarity

If the SSD purchased has asymmetrical blocking characteristics and it is being connected between a cathodically protected structure and ground, connect the negative terminal of the SSD to the cathodically protected structure and the positive terminal to ground. If being connected between two different cathodically protected systems, attach the negative terminal to the more negative structure and the positive terminal to the less negative structure. A label on the SSD housing shows the polarity of each terminal.

Model Number Chart

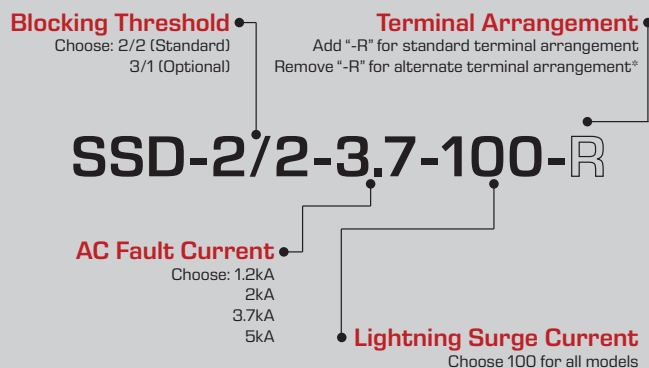

Certifications

The SSD has been tested by Nationally Recognized Testing Laboratories (NRTLs) for compliance to independent standards in its operation, ratings, and construction. This includes compliance to standards for:

Class I, Div. 2, Groups A, B, C, D and Zone 2, Group IIC

Class & Division System:

UL (United States) and C-UL (Canada)

- Effective Ground Fault Current Path per:
 - NFPA 70 (US National Electric Code – NEC): Article 250.4(A)(5)
 - CSA C22.1 (Canadian Electric Code, Part I): 10-100 & 10-500
- Isolation of Objectionable DC Ground Currents per:
 - NFPA 70: Article 250.6(E)
 - CSA C22.1: 10-100 & 10-500
- Hazardous Location Use:
 - Class 1, Division 2, Groups A, B, C, D by UL & C-UL per:
 - UL 121201, 9th Ed. and CSA C22.2 No.213-17
- Safety Requirements for Electrical Equipment per:
 - UL 61010-1, 3rd Ed. & CSA C22.2 No. 61010-1
 - Overvoltage Protection from Impulse (Lightning) Current: 100kA (8 x 20µs)
 - Enclosure Rating: IP68 (Submersible to 2 meters depth)
 - Temperature Range: -45°C to +65°C (-49°F to +149°F)

Zone System: ATEX / IECEx / UKEx (Europe / International / UK). ATEX per directive 2014/34/EU (Equipment for use in Potentially Explosive Atmospheres):

- Zone 2, Group IIC, Increased Safety "ec"
- EN IEC 60079-0: 2018
- EN IEC 60079-7: 2015+A1:2018
- IEC 60079-0: 2017
- IEC 60079-7: 2017
- Overvoltage Protection from Impulse (Lightning) Current: 100kA (8 x 20µs)
- Temperature Range: -45°C to +65°C
- Enclosure Rating: IP68



Enclosure

The standard enclosure is rated IP68 to 2m depth (comparable to NEMA 6P). This enclosure is suitable for submersible applications.

Field Testing

Before installation, the following measurements are suggested to confirm that the steady-state conditions imposed on the SSD will be within its ratings.

1. Measure the open-circuit DC voltage between the SSD connection points with a multimeter. The open-circuit DC voltage measured should be within the DC blocking voltage rating of the model selected (i.e., normally $-3.0\text{ V}/+1.0\text{ V}$ or $+/-2.0\text{ V}$, unless a custom version has been ordered).
2. Measure the steady-state short-circuit AC-RMS current between the SSD connection points with a clamp-on ammeter. The short-circuit AC-RMS steady-state current measured should be less than the steady-state AC current rating of the SSD model ordered.
3. After installation, the DC voltage across the SSD terminals can be measured to confirm that the expected value of cathodic protection voltage exists, assuming the cathodic protection system is ON. (The voltage measured with a voltmeter will be less than the actual cathodic protection voltage because it is not being measured with respect to a reference cell.)
4. After installation, the steady-state AC current through the SSD conductors can again be measured. The current measured should be comparable to the value measured prior to installation since the AC impedance of the SSD is negligible (i.e., about 10 milliohms at 60 Hz).
5. To verify correct device operation while in service, measure the pipe to soil voltage using a reference cell. An acceptable CP reading will indirectly indicate correct operation with DC isolation, as device conduction would bond the CP system to ground (or to the other connected structure) and affect the CP reading. While an indirect test, it has proven to be a good indicator of operation. An unacceptable reading may be due to other factors besides the Dairyland device, and if needed perform the following additional tests.

6. The definitive test is one performed with the device out of circuit. If the device is in service, disconnect the CP structure attachment conductor (typically at the negative terminal) so that the product is isolated, but first addressing any safety issues such as adding a current-rated bonding jumper between the two connection points, wearing insulating gloves, etc. Note that if the Dairyland device is performing mitigation of induced AC voltage, disconnecting the device will leave the structure as an open circuit, and the induced voltage on the pipeline may rise to high levels. Therefore, take appropriate safety measures before proceeding. Next, momentarily short the device terminals to remove any residual charge that may be on the internal capacitor. Connect a multi-meter, set to the lowest Ohms scale, across the terminals. If the product is functional, the resistance will start at zero ohms and then very slowly increase as the capacitor in the decoupler begins to charge from the multi-meter. The test may be discontinued at this point, as charging the capacitor can take up to 10 minutes, and it is only necessary to observe this general response briefly. If the product is failed, the reading will remain fixed and at a very low resistance value, typically a fraction of one Ohm.

If any measurements do not produce the expected results, contact Dairyland.

GENERAL COMMENTS

The SSD does not require routine maintenance, but if the cathodic protection voltage level near the SSD is below the normal or expected value, it is suggested that the unit be field tested following procedures available from Dairyland.

If a problem is suspected, contact Dairyland for troubleshooting assistance. If repairs are necessary the unit is to be returned to Dairyland for diagnosis and repair after requesting a Return Material Authorization (RMA).

The SSD is designed to fail as a short-circuit to assure safety grounding at all times if the unit fails due to excessive AC fault current or lightning current beyond rating.

CUSTOMERSERVICE@DAIRYLAND.COM

P.O. Box 187
Stoughton, WI 53589, USA



ATEX AND IECEX COMMENTS

- The device shall be placed into service in accordance with the ratings and limitations stated in the installation and operating instructions.
- No ongoing maintenance is required, as the device is designed to be maintenance-free, and is of solid-state construction with no moving, wearing, or serviceable parts.
- During installation the device should be handled and mounted in a location so that direct impact is minimized.
- Regular testing of the device is not required. Users who desire to verify the operating condition of the device should refer to the section entitled “Field Testing.” Observe all safety precautions described, in addition to industry or company safety practices.
- **WARNING:** Potential electrostatic charging hazard – Plastic enclosures are to be cleaned or wiped only with a damp cloth.
- Products marked CE, Ex II 3 G are Equipment Group II, Equipment Category 3, and comply with the Essential Health and Safety Requirements relating to the design and construction of such equipment given in Annex II to the Directive 2014/34/EU.
- This equipment is intended for use in area in which explosive atmospheres caused by gasses, vapors, mists, air or dust mixtures are unlikely to occur, or are likely to occur only infrequently and for short periods. Such locations correspond to Zone 2 classification according to ATEX Directive 2014/34/EU.
- This equipment complies with standards listed per certificate numbers DEMKO 05 ATEX 0431689X and IECEx UL 14.0021X and UL21UKEX2249X.
- This equipment is marked: **CE** **Ex** II 3 G Ex ec IIC T4 Gc

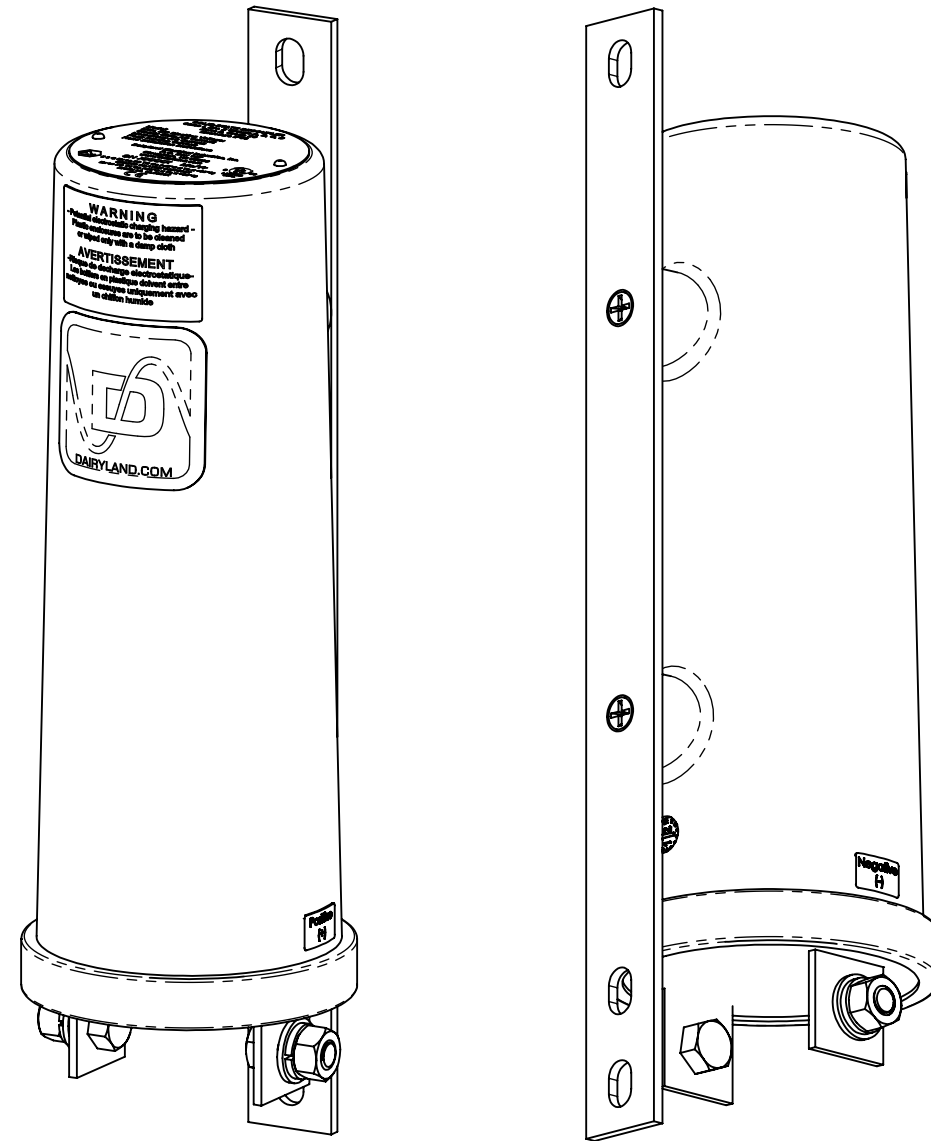
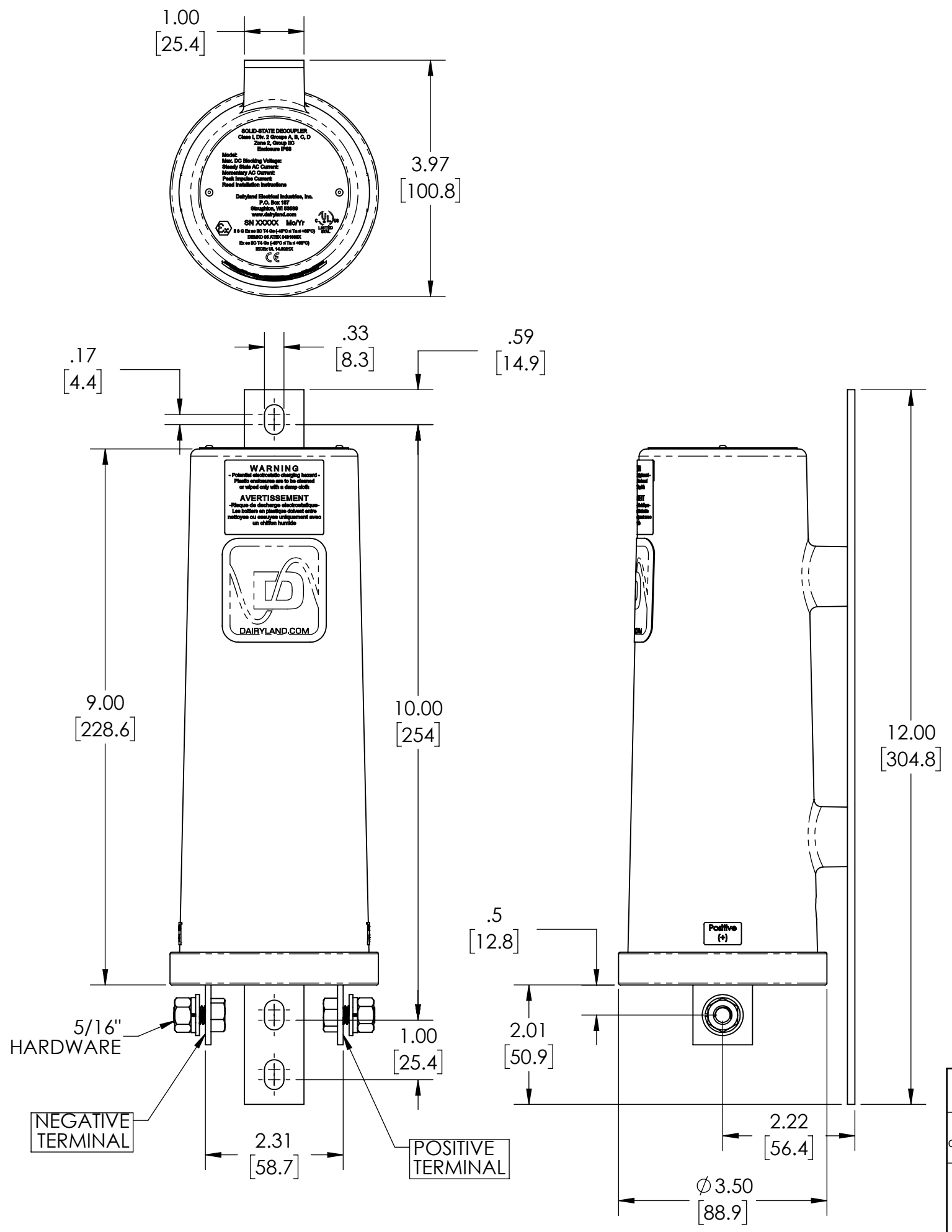

NOTE: THIS SHEET APPLIES TO ALL SSD MODELS WITH STANDARD TERMINAL ARRANGEMENT (-R MODEL NUMBERS).

ASME Y14.5M 2018 APPLIES UNLESS OTHERWISE SPECIFIED DIMENSIONS ARE IN INCHES. COMPUTER-GENERATED DRAWING DO NOT EDIT MANUALLY. .XXX = ±.005" .XX = ±.01" .X = ±.03" ANGLES = ±1°	MATERIAL: NA	DRAWN: JSJ	DATE DRAWN: 01/21/2021	 DAIRYLAND ELECTRICAL INDUSTRIES, INC. P.O. BOX 187 STOUGHTON, WI 53589 608-877-9900 DAIRYLAND.COM
	FINISH: NA	DWG APPROVAL: RJH	DATE APPROVAL: 07/02/2021	
TITLE: SSD OUTLINE DRAWING				
THE INFORMATION CONTAINED IN THIS DRAWING IS THE SOLE PROPERTY OF DAIRYLAND ELECTRICAL INDUSTRIES, INC. ANY REPRODUCTION IN PART OR WHOLE, WITHOUT THE WRITTEN PERMISSION OF DAIRYLAND ELECTRICAL INDUSTRIES, INC. IS PROHIBITED.		SHEET: 1 OF 2	DWG SIZE: B	SCALE: 1:2
			REV: A	PART #: 100135

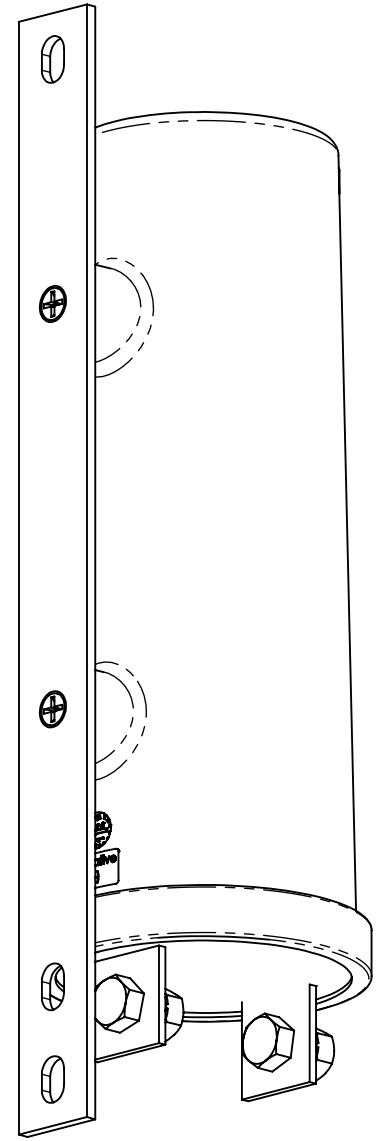
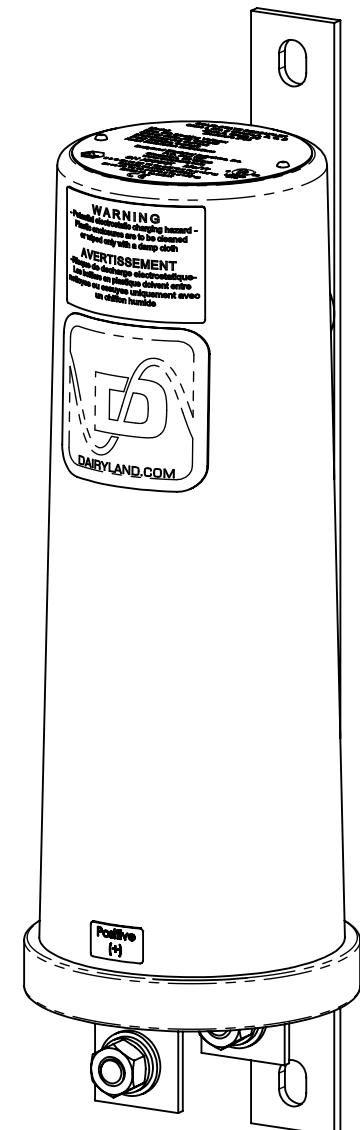
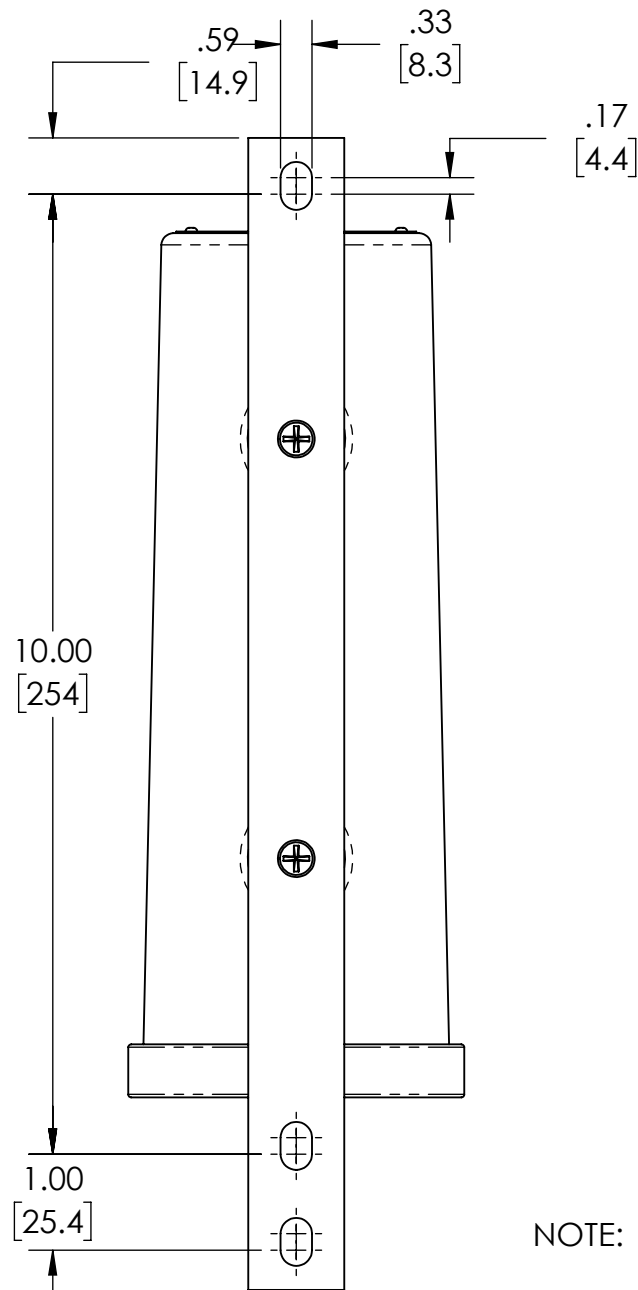
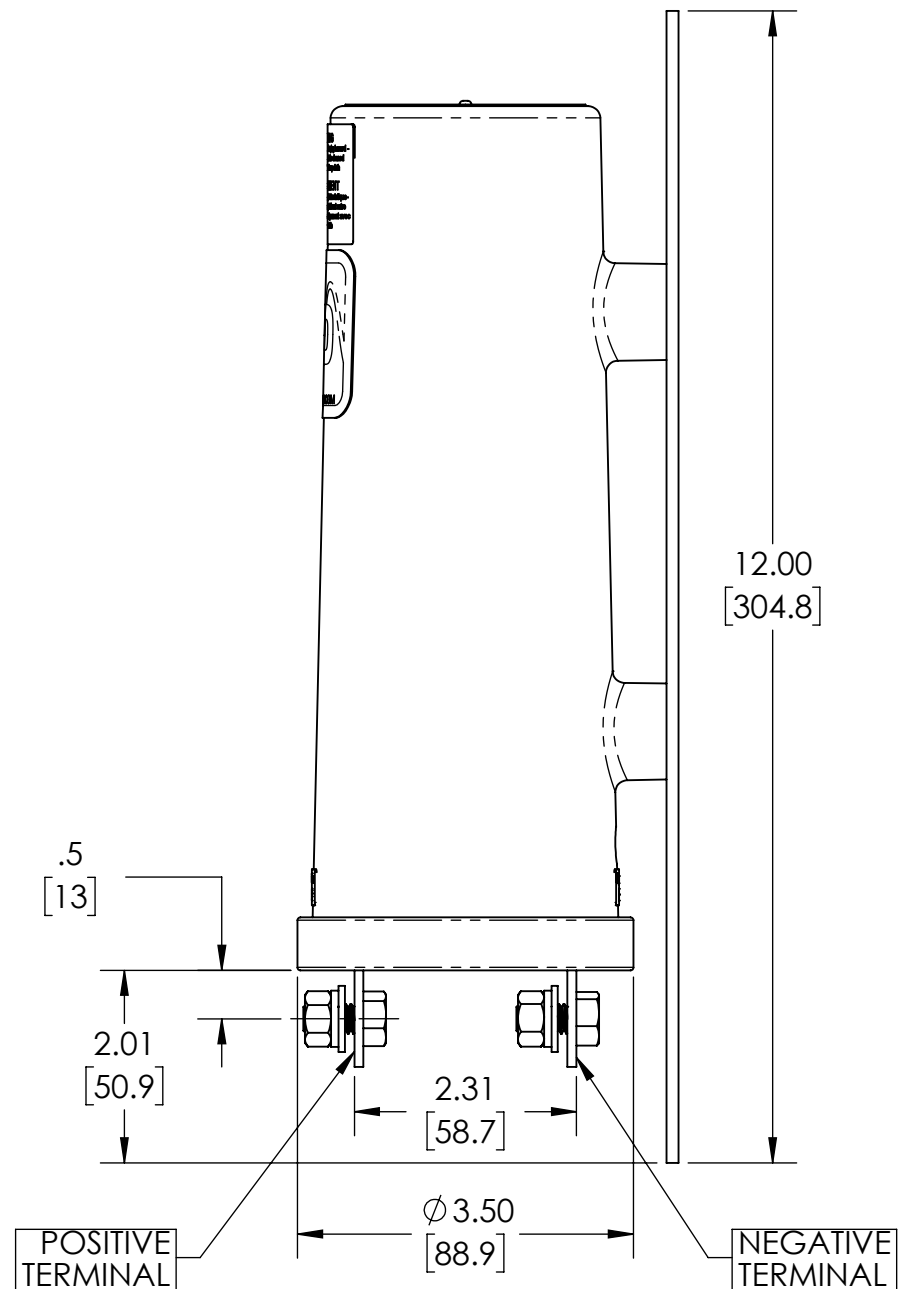
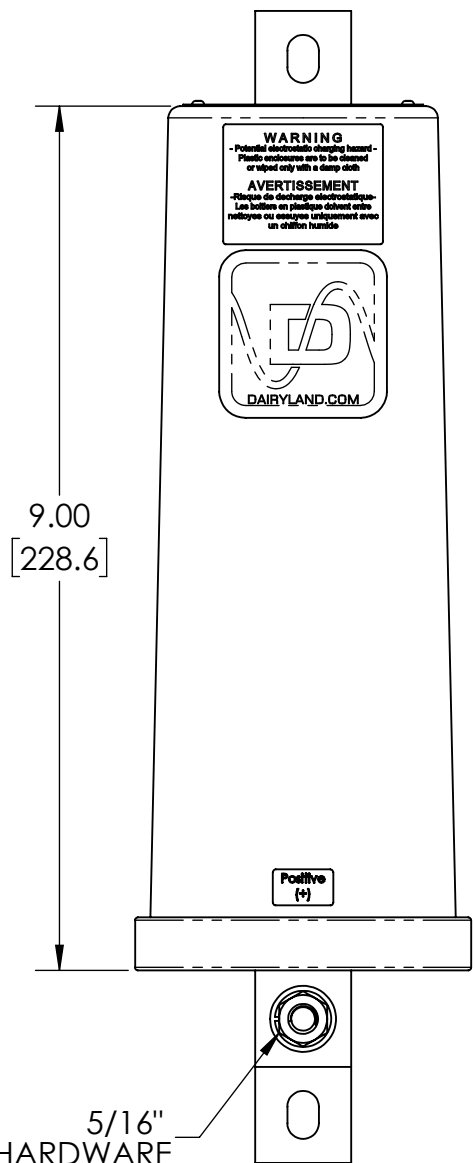
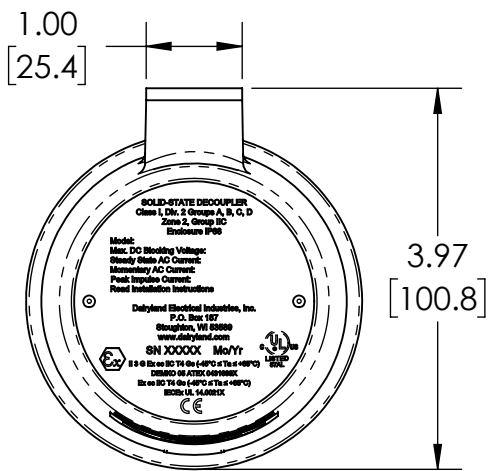

NOTE: THIS SHEET APPLIES TO ALL SSD MODELS WITH AN OPTIONAL TERMINAL ARRANGEMENT (NON -R MODEL NUMBERS).

ASME Y14.5M 2018 APPLIES 	MATERIAL: NA	DRAWN: JSJ	DATE DRAWN: 01/21/2021	 DAIRYLAND ELECTRICAL INDUSTRIES, INC. P.O. BOX 187 STOUGHTON, WI 53589 608-877-9900 DAIRYLAND.COM
UNLESS OTHERWISE SPECIFIED DIMENSIONS ARE IN INCHES. COMPUTER-GENERATED DRAWING DO NOT EDIT MANUALLY.	FINISH: NA	DWG APPROVAL: RJH	DATE APPROVAL: 07/02/2021	
.XXX = ±.005" .XX = ±.01" .X = ±.03" ANGLES = ±1°	TITLE: SSD OUTLINE DRAWING			
THE INFORMATION CONTAINED IN THIS DRAWING IS THE SOLE PROPERTY OF DAIRYLAND ELECTRICAL INDUSTRIES, INC. ANY REPRODUCTION IN PART OR WHOLE, WITHOUT THE WRITTEN PERMISSION OF DAIRYLAND ELECTRICAL INDUSTRIES, INC. IS PROHIBITED.	SHEET: 2 OF 2	DWG SIZE: B	SCALE: 1:2	REV: A PART #: 100135